

Waterproof Connectors with Crimp Contacts Compatible with JIS-B-6015

CE01 Series



◆ OUTLINE

CE01 series is compatible with JIS-B 6015, Japanese Industrial Standards, and is superior in waterproof and dustproof connector which has a ground contact to protect a circuit.

This connector is ideal for use under the external condition such as industrial equipment which needs to withstand moisture, oil, and dust.



◆ FEATURES

- Five-key position prevents cross-plugging problems and one touch lock design is capable to lock surely with click note. (Bayonet Coupling)
- Receptacle connector has an o-ring which conforms to meet IP67 to prevent moisture, oil and dust when the connectors are mated. Besides, when the plug connector uses a conduit with an o-ring, both plug and receptacle can be waterproof.
- Connectors are provided with a premating and ground contact having conductivity with the shell to protect a circuit. The premating contact is mated first before the other contacts and dismated last when dismating the connector.
- Contact is crimp type and easy to terminate. Also it is easy to extract the contact from the insert by the extraction tool.
- UL approved (File No. E72124)

◆ SPECIFICATIONS



Rated Current	Contact Size	#20	#16	#12	#8
	Maximum Rating per Contact	5A	13A	23A	46A
Rated Voltage	Service Rating	INST		A	D
	AC(r.m.s.)	200		500	900
	DC	250		700	1,250
Dielectric Withstanding Voltage	AC(r.m.s.)/1 minute	1,000		2,000	2,800
Insulation Resistance	5,000M Ω min. at 500VDC				
Contact Resistance	Contact Size	#20	#16	#12	#8
	m Ω max.	8	4	2	0.6
Operating Temperature	-55°C to +125°C				
Humidity	95% max.				

◆ MATERIAL / FINISH

Item	Material / Finish
Shell	Aluminum Alloy / Zinc Plating, Black Trivalent Chromium Treatment
Coupling Ring	Aluminum Alloy / Zinc Plating, Black Trivalent Chromium Treatment
Insert	Polyester Resin (UL94V-0) Gray
Contact	Copper Alloy / Silver Plating
O Ring	Nitrile Rubber
Ground Clip	Copper Alloy / Silver Plating
Gasket	Polychloroprene or Ethylenepropylene Rubber

© Specifications and/or dimensions in this catalog are subject to change without notice.
Your checking the latest specifications with our drawings would be highly appreciated.

Conforming
Standard

JIS B 6015

Waterproof

IP67

Lock Type

Bayonet

▶ Insert Arrangement List

Front View of Pin Insert or Rear View of Socket Insert

Number of Contact	4	5	7		8
Insert Arrangement					
Insert Number	22-22	18-11	20-15	24-10	22-23
Contact Size	#8	#12	#12	#8	#12
Service Rating	A	A	A	A	D(4), A(Others)

Number of Contact	10	17	19		24
Insert Arrangement					
Insert Number	18-1	20-29	18-19A	22-14	24-28
Contact Size	#16	#16	#20	#16	#16
Service Rating	A(3,5,6,8) / INST(Others)	A	INST	A	INST

Number of Contact	30	37	52	73
Insert Arrangement				
Insert Number	20-30A	28-21	24-52A	28-73A
Contact Size	#20	#16	#20	#20
Service Rating	INST	A	INST	INST

Note: Normal key position illustrated.

▶ Alternate Insert Positions

Number of Contact	Insert No	W	X	Y	Z
4	22-22	—	160	—	300
5	18-11	—	170	265	—
7	20-15	80	—	—	280
	24-10	80	—	—	280
8	22-23	85	—	—	—
10	18-1	70	145	260	290
17	20-29	80	—	—	280
19	18-19A	80	110	250	280
	22-14	75	150	—	285
24	24-28	80	110	250	280
30	20-30	80	110	250	280
37	28-21	80	110	250	280
52	24-52A	80	110	250	280
73	28-73A	80	110	250	280

To avoid cross-plugging problems in applications requiring the use of more than one connector of the same size and arrangement, alternate insert positions are available as indicated in the chart.

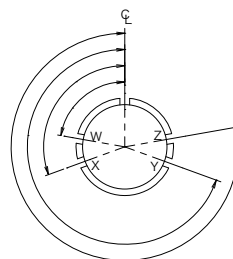

Front View of Pin Insert

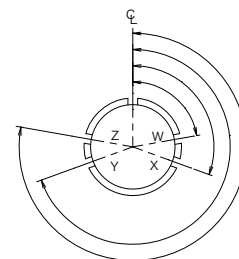

Front View of Socket Insert

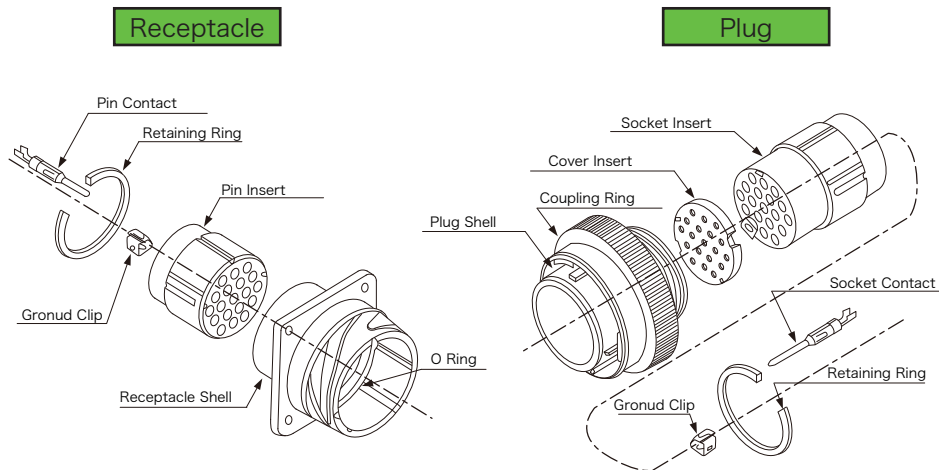
Diagram

Note: Cover insert is available for socket insert with #16 or #20 contacts only.

Cable Receptacle
CE01-1A22-14PCW-D0
 ① ② ③ ④ ⑤ ⑥ ⑦ ⑧

① Connector Style	1A : Cable Receptacle
② Shell Size	18, 20, 22, 24 and 28
③ Insert Arrangement	Refer to page 2.
④ Contact Style	P : Pin Contact S : Socket Contact
⑤ Contact Type	C : Crimp Contact
⑥ Alternate Insert Position	Omit : Standard Position W, X, Y, Z : Refer to page 3.
⑦ Plating /Finish	D : Zinc Plating / Black Trivalent Chromium Treatment
⑧ Contact	0 : Less Contact (Available separately)

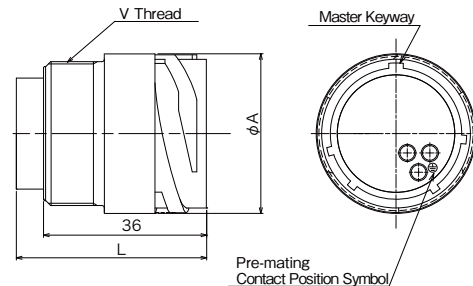

Shell Size	Number of Contact	Part Number	A	V	Contact Size	L. Min.	
						Pin Insert	Socket Insert
18	5	CE01-1A18-11 □ C-D0	28.87	1-20UNEF-2A	# 12	46	43.0
	10	CE01-1A18-1 □ C-D0			# 16	43	38.0
	19	CE01-1A18-19A □ C-D0			# 20	40	36.5
20	7	CE01-1A20-15 □ C-D0	33.95	1 1/8-18UNEF-2A	# 12	46	43.0
	17	CE01-1A20-29 □ C-D0			# 16	43	38.0
	30	CE01-1A20-30A □ C-D0			# 20	40	36.5
22	4	CE01-1A22-22 □ C-D0	35.22	1 1/4-18UNEF-2A	# 8	48	48.0
	8	CE01-1A22-23 □ C-D0			# 12	46	43.0
	19	CE01-1A22-14 □ C-D0			# 16	43	38.0
24	7	CE01-1A24-10 □ C-D0	38.39	1 3/8-18UNEF-2A	# 8	48	48.0
	24	CE01-1A24-28 □ C-D0			# 16	43	38.0
	52	CE01-1A24-52A □ C-D0			# 20	40	36.5
28	37	CE01-1A28-21 □ C-D0	44.74	1 5/8-18UNEF-2A	# 16	43	38.0
	73	CE01-1A28-73A □ C-D0			# 20	40	36.5

© Specifications and/or dimensions in this catalog are subject to change without notice.
 Your checking the latest specifications with our drawings would be highly appreciated.

▶ Box Mount Receptacle

CE01-2A22-14PCW-D OS

① ② ③ ④ ⑤ ⑥ ⑦ ⑧ ⑨

① Connector Style	2A : Box Mount Receptacle
② Shell Size	18, 20, 22, 24 and 28
③ Insert Arrangement	Refer to page 2.
④ Contact Style	P : Pin Contact S : Socket Contact
⑤ Contact Type	C : Crimp Contact
⑥ Alternate Insert Position	Omit : Standard Position W, X, Y, Z : Refer to page 3.
⑦ Plating /Finish	D : Zinc Plating / Black Trivalent Chromium Treatment
⑧ Contact	0 : Less Contact (Available separately)
⑨ Gasket	Omit : Less Gasket S : With Gasket

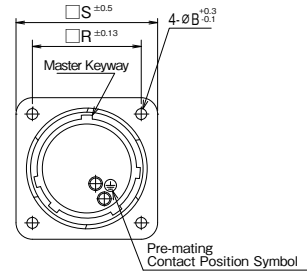
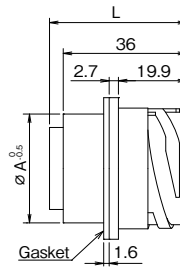

Note: Gasket is applicable to box receptacle only.

Place a gasket on the rear of the flange. (thickness 1.6mm)

Shell Size	Number of Contact	Part Number	A	B	S	R	Contact Size	L. Min.	
								Pin Insert	Socket Insert
18	5	CE01-2A18-11 □ C-D0	24.9	3.2	35.0	26.97	# 12	46	43.0
	10	CE01-2A18-1 □ C-D0					# 16	43	38.0
	19	CE01-2A18-19A □ C-D0					# 20	40	36.5
20	7	CE01-2A20-15 □ C-D0	29.6	3.2	38.1	29.36	# 12	46	43.0
	17	CE01-2A20-29 □ C-D0					# 16	43	38.0
	30	CE01-2A20-30A □ C-D0					# 20	40	36.5
22	4	CE01-2A22-22 □ C-D0	31.8	3.2	41.3	31.75	# 8	48	48.0
	8	CE01-2A22-23 □ C-D0					# 12	46	43.0
	19	CE01-2A22-14 □ C-D0					# 16	43	38.0
24	7	CE01-2A24-10 □ C-D0	35.0	4.2	44.3	34.92	# 8	48	48.0
	24	CE01-2A24-28 □ C-D0					# 16	43	38.0
	52	CE01-2A24-52A □ C-D0					# 20	40	36.5
28	37	CE01-2A28-21 □ C-D0	41.3	4.2	50.8	39.67	# 16	43	38.0
	73	CE01-2A28-73A □ C-D0					# 20	40	36.5

▶ Straight Plug

CE01-6A22-14PCW-D 0

① ② ③ ④ ⑤ ⑥ ⑦ ⑧

① Connector Style	6A : Straight Plug
② Shell Size	18, 20, 22, 24 and 28
③ Insert Arrangement	Refer to page 2.
④ Contact Style	P : Pin Contact S : Socket Contact
⑤ Contact Type	C : Crimp Contact
⑥ Alternate Insert Position	Omit : Standard Position W, X, Y, Z : Refer to page 3.
⑦ Plating / Finish	D : Zinc Plating / Black Trivalent Chromium Treatment
⑧ Contact	0 : Less Contact (Available separately)

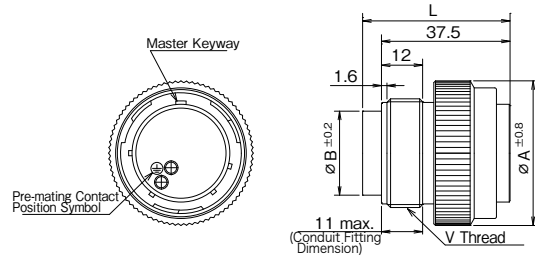

Shell Size	Number of Contact	Part Number	A	B	V	Contact Size	L Max.	
							Pin Insert	Socket Insert
18	5	CE01-6A18-11 □ C-D0	35.9	23.5	1-20UNEF-2A	# 12	46	43.0
	10	CE01-6A18-1 □ C-D0				# 16	43	38.0
	19	CE01-6A18-19A □ C-D0				# 20	40	37.5
20	7	CE01-6A20-15 □ C-D0	40.6	26.9	1 1/8-18UNEF-2A	# 12	46	43.0
	17	CE01-6A20-29 □ C-D0				# 16	43	38.0
	30	CE01-6A20-30A □ C-D0				# 20	40	37.5
22	4	CE01-6A22-22 □ C-D0	42.2	29.6	1 1/4-18UNEF-2A	# 8	48	48.0
	8	CE01-6A22-23 □ C-D0				# 12	46	43.0
	19	CE01-6A22-14 □ C-D0				# 16	43	38.0
24	7	CE01-6A24-10 □ C-D0	45.4	32.8	1 3/8-18UNEF-2A	# 8	48	48.0
	24	CE01-6A24-28 □ C-D0				# 16	43	38.0
	52	CE01-6A24-52A □ C-D0				# 20	40	37.5
28	37	CE01-6A28-21 □ C-D0	51.7	39.0	1 5/8-18UNEF-2A	# 16	43	38.0
	73	CE01-6A28-73A □ C-D0				# 20	40	37.5

▶ Waterproof Straight Backshell

CE01-22BSL-D S

① ② ③ ④ ⑤ ⑥

① Shell Size	18, 20, 22, 24 and 28
② Part	B : Backshell
③ Style	S : Straight
④ Shell Type	Omit : Standard Backshell L : Long Backshell
⑤ Finish	D : Black Trivalent Chromium Treatment
⑥ Waterproof	S : Waterproof

MATERIAL / FINISH

Aluminum Alloy/Black Trivalent Chromium Treatment

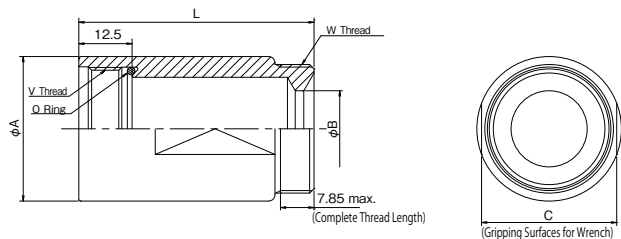

The straight backshell retains the cable when the conduit is not used. Two kinds of backshells in different length are available for the shell size of 22, 24 and 28. Use the waterproof backshell with the waterproof cable clamp.

Shell Size	Part Number	A	B	C	V	W	L
18	CE01-18BS-DS	29.3	16.3	26.73	1-20UNEF-2B	1-20UNEF-2A	55
20	CE01-20BS-DS	33.8	17.8	31.6	1 1/8-18UNEF-2B	1 3/16-18UNEF-2A	55
22	CE01-22BS-DS	35.3	17.8	32.4	1 1/4-18UNEF-2B	1 3/16-18UNEF-2A	55
	CE01-22BSL-DS						75
24	CE01-24BS-DS	38.8	21.0	36.6	1 3/8-18UNEF-2B	1 7/16-18UNEF-2A	55
	CE01-24BSL-DS						75
28	CE01-28BS-DS	44.8	21.0	40.0	1 5/8-18UNEF-2B	1 7/16-18UNEF-2A	55
	CE01-28BSL-DS						75

Note : Use the long backshell in the case of insert arrangements with the contact size #12 and #8.

▶ Straight Backshell

CE01-22BSL-D

① ② ③ ④ ⑤

① Shell Size	18, 20, 22, 24 and 28
② Part	B : Backshell
③ Style	S : Straight
④ Shell Type	Omit : Standard Backshell L : Long Backshell
⑤ Finish	D : Black Trivalent Chromium Treatment

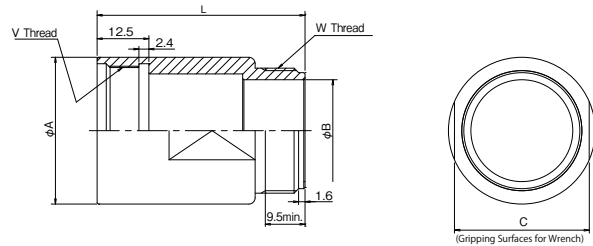

MATERIAL / FINISH

Aluminum Alloy/Black Trivalent Chromium Treatment

The straight backshell retains the cable when the conduit is not used. Two kinds of backshells in different length are available for the shell size of 22, 24 and 28.

Use the waterproof backshell with the waterproof cable clamp.

Shell Size	Part Number	A	B	C	V	W	L
18	CE01-18BS-D	29.3	19.5	26.73	1-20UNEF-2B	1-20UNEF-2A	50
20	CE01-20BS-D	33.8	24.5	31.6	1 1/8-18UNEF-2B	1 3/16-18UNEF-2A	50
22	CE01-22BS-D	35.3	24.5	32.4	1 1/4-18UNEF-2B	1 3/16-18UNEF-2A	50
	70						
24	CE01-24BS-D	38.8	30.5	36.6	1 3/8-18UNEF-2B	1 7/16-18UNEF-2A	50
	CE01-24BSL-D						70
28	CE01-28BS-D	44.8	30.5	40.0	1 5/8-18UNEF-2B	1 7/16-18UNEF-2A	50
	CE01-28BSL-D						70

Note : Use the long backshell in the case of insert arrangements with the contact size #12 and #8.

▶ Waterproof Angle Backshell

CE-18BA-S-D

① ② ③ ④ ⑤

① Shell Size	18, 20, 22, 24 and 28
② Part	B : Backshell
③ Style	A : Angle
④ Waterproof	S : Waterproof
⑤ Finish	D : Black Trivalent Chromium Treatment

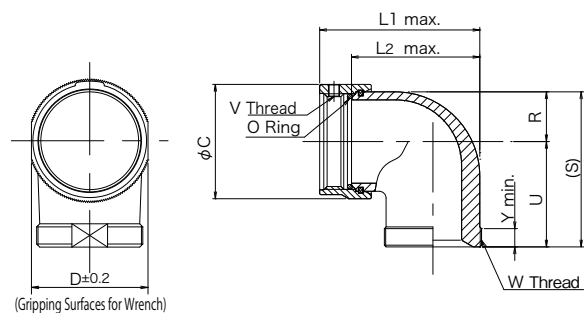

MATERIAL / FINISH

Aluminum Alloy/Black Trivalent Chromium Treatment

Shell Size	Part Number	L1	L2	C	D	R	U	(S)	V	W	Y
18	CE-18BA-S-D	44.6	34.0	32.4	30.0	13.2	30.2	(43.4)	1-20UNEF-2B	1-20UNEF-2A	7.5
20	CE-20BA-S-D	50.5	39.6	36.0	33.6	15.0	33.3	(48.3)	1 1/8-18UNEF-2B	1 3/16-18UNEF-2A	7.5
22	CE-22BA-S-D	50.5	39.6	38.6	36.2	16.3	33.3	(49.6)	1 1/4-18UNEF-2B	1 3/16-18UNEF-2A	7.5
24	CE-24BA-S-D	60.1	47.9	42.4	40.0	18.2	36.5	(54.7)	1 3/8-18UNEF-2B	1 7/16-18UNEF-2A	7.5
28	CE-28BA-S-D	60.9	47.9	49.5	46.4	21.3	36.5	(57.8)	1 5/8-16UN-2B	1 7/16-18UNEF-2A	7.5

· The waterproof angle backshell retains the cable when the conduit is not used.

Waterproof Cable Clamp

CE3057- □□ A- □ - D
① ② ③

① Clamp Size	10, 12 and 16
② Bushing Size	Rubber Bushing (Refer to the applicable cable size.)
③ Finish	D : Black Trivalent Chromium Treatment

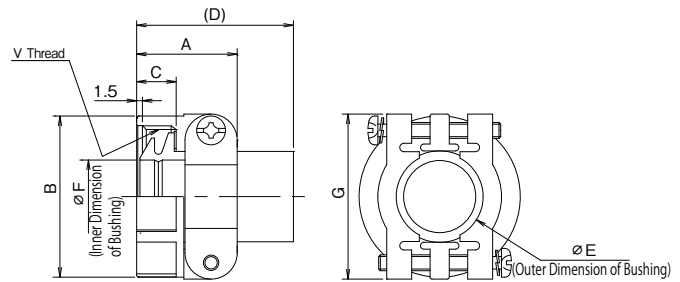

MATERIAL / FINISH

	Material	Finish
Cable Clamp Body and Metal Fastener	Aluminum Alloy	Black Trivalent Chromium Treatment
Bushing	Synthetic Rubber	Black

Part Number	Applicable Shell Size	A	B	C	(D)	E	F	G	V	Bushing P/N	Applicable Cable
CE3057-10A-1-D	18	23.83	30.1	10.31	(41.3)	15.8	14.1	31.7	1-20UNEF-2B	CE3420-10-1	φ 10.5 ~ φ 14.1
11.0							CE3420-10-2			φ 8.5 ~ φ 11	
8.7							CE3420-10-3			φ 6.5 ~ φ 8.7	
CE3057-12A-1-D	20	23.83	35.0	10.31	(41.3)	19.0	16.0	37.3	1 3/16-18UNEF-2B	CE3420-12-1	φ 12.5 ~ φ 16
13.0							CE3420-12-2			φ 9.5 ~ φ 13	
10.0							CE3420-12-3			φ 6.8 ~ φ 10	
CE3057-12A-3-D	22						17.0			CE3420-12-7	φ 14.5 ~ φ 17
CE3057-16A-1-D	24	26.19	42.1	10.31	(41.3)	23.8	19.1	42.9	1 7/16-18UNEF-2B	CE3420-16-1	φ 15 ~ φ 19.1
CE3057-16A-2-D							15.5			CE3420-16-2	φ 13 ~ φ 15.5
CE3057-16A-4-D							21.5			CZY005-GB-3	φ 19.1 ~ φ 21.5
CE3057-16A-6-D							20.0			CE3420-16-6	φ 18.5 ~ φ 20
CE3057-16A-7-D							13.5			CE3420-16-7	φ 11.5 ~ φ 13.5
CE3057-16A-8-D							12.5			CZY005-GB-5	φ 10.5 ~ φ 12.5

* CE3057- □□ A- □ - D is a waterproof cable clamp for use with D/MS(D190), CE01 and CE02 plugs.
The main body is the same as D/MS3057A- □□ . The cable clamp has a waterproof rubber bushing.
Make sure to use a cable meeting one of the applicable cable size ranges as shown in the chart.
The cable clamp should be used together with the waterproof backshell.

Cable Clamp

D/MS3057- □□ A
①

① Clamp Size	10, 12 and 16
--------------	---------------

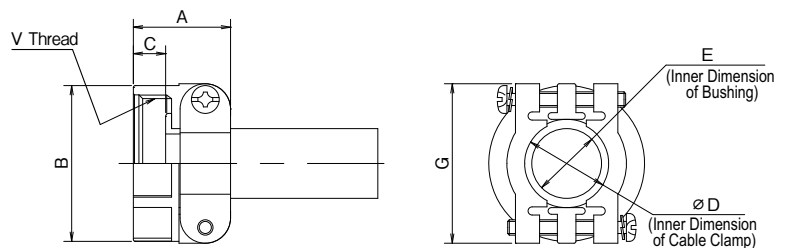

MATERIAL / FINISH

	Material	Finish
Cable Clamp Body and Metal Fastener	Aluminum Alloy	Black Trivalent Chromium Treatment
Bushing	Synthetic Rubber	Black

Part Number	Applicable Shell Size	A	B	C	D	E	G	V	Bushing P/N
D/MS3057-10A	18	23.83	30.1	10.3	15.9	14.3	31.7	1-20UNEF	AN3420-10
D/MS3057-12A	20, 22	23.83	35.0	10.3	19.0	15.9	37.3	1 3/16-18UNEF	AN3420-12
D/MS3057-16A	24, 28	26.19	42.1	10.3	23.8	19.1	42.9	1 7/16-18UNEF	AN3420-16

* D/MS3057- □□ A is an accessory which is used together with a backshell to fasten the cable.
The cable is fixed in the center of the cable clamp for sure since the cable is fixed from both directions with two pieces of the metal clamps and the screws. The jacketed cable can be used with this cable clamp as well because a rubber bushing shown on the table above is inserted.

© Specifications and/or dimensions in this catalog are subject to change without notice.
Your checking the latest specifications with our drawings would be highly appreciated.

▶ Waterproof Rubber Bushing

CE3420- -
 ① ②

① Cable Clamp Size	10, 12 and 16
② Bushing Size	Refer to Table 1.

MATERIAL

Synthetic Rubber(Black)

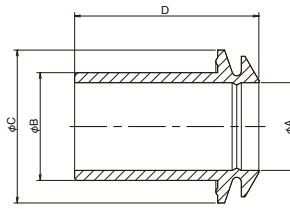

CE3420- - is a rubber bushing which is inserted into the cable clamp, CE3057- -A- ,to constrict the cable to meet the waterproof requirement.

Table 1

Part Number	φ A	φ B	φ C	D	Friction Washer
CE3420-10-1	14.1	15.5	22.2	38.5	MS3057-10W
CE3420-10-2	11.0	15.5	22.2	38.5	
CE3420-10-3	8.7	15.5	22.2	38.5	
CE3420-12-1	16.0	18.6	26.9	39.3	MS3057-12W
CE3420-12-2	13.0	18.6	26.9	39.3	
CE3420-12-3	10.0	18.6	26.9	39.3	
CE3420-16-1	19.1	23.4	33.2	40.0	MS3057-16W
CE3420-16-2	15.5	23.4	33.2	40.0	

Purchase a friction washer separately.

▶ Rubber Bushing

AN3420-
 ①

① Cable Clamp Size	10, 12 and 16
--------------------	---------------

MATERIAL

Synthetic Rubber(Black)

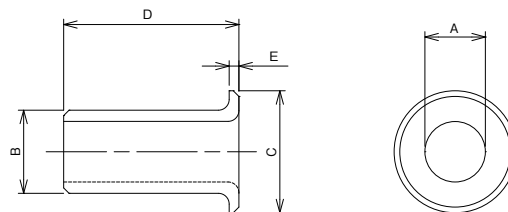

Part Number	φ A	φ B	φ C	D±0.7	E
AN3420-10	14.3	15.6	23.7	60.3	2.3
AN3420-12	15.9	18.8	28.2	57.2	2.3
AN3420-16	19.1	23.6	35.0	54.0	2.9

▶ Rubber Protection Cap for Receptacle

CE01RC- RA

①

① Shell Size	18, 20, 22, 24 and 28
--------------	-----------------------

MATERIAL

Synthetic Rubber(Black)

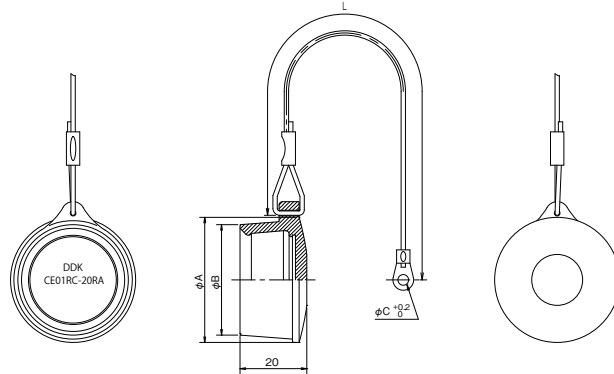

Shell Size	Part Number	A	B	C	L
18	CE01RC-18RA	37.5	33.1	3.2	80
20	CE01RC-20RA	42.6	38.2	3.2	100
22	CE01RC-22RA	43.8	39.4	3.2	110
24	CE01RC-24RA	47.0	42.6	4.3	130
28	CE01RC-28RA	53.3	49.0	4.3	150

▶ Metal Protection Cap for Receptacle

CE01RC- -D

①

②

① Shell Size	18, 20 and 28
② Finish	D : Black Trivalent Chromium Treatment

MATERIAL / FINISH

Aluminum Alloy/Black Trivalent Chromium Treatment

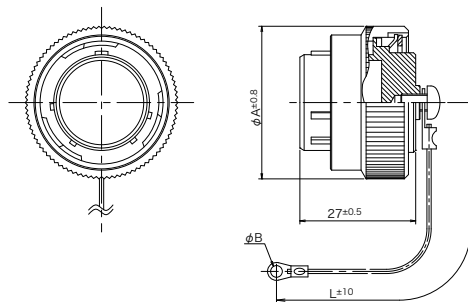

Shell Size	Part Number	A	B	L
18	CE01RC-18-D	35.9	3.2	80
20	CE01RC-20-D	40.6	3.2	100
28	CE01RC-28-D	51.7	4.3	150

▶ Contact(Crimp Type)

Part Number			Contact Type	Applicable Cable(Twisted Wire)		
Package	Pin Contact	Socket Contact		AWG#	Sectional Area(mm ²)	Jacket Dia.
Separate (100pcs/bag)	CE01- # 20P-C2-100	CE01- # 20S-C2-100	Press	# 26 ~ # 24	0.13 ~ 0.2	φ 1.2 ~ φ 1.5
	CE01- # 20P-C1-100	CE01- # 20S-C1-100		# 22	0.3	φ 1.4 ~ φ 1.7
Reel (1,000pcs/reel)	CE01- # 20P-C2-10000	CE01- # 20S-C2-10000		# 22 ~ # 18	0.3 ~ 0.75	φ 2.3 max.
	CE01- # 20P-C1-10000	CE01- # 20S-C1-10000		# 26 ~ # 24	0.13 ~ 0.2	φ 1.2 ~ φ 1.5
Separate (100pcs/bag)	CE01- # 16P-2024-100	CE01- # 16S-2024-100		# 22	0.3	φ 1.4 ~ φ 1.7
	CE01- # 16P-1620-100	CE01- # 16S-1620-100		# 22 ~ # 18	0.3 ~ 0.75	φ 2.3 max.
	CE01- # 16P-1416-100	CE01- # 16S-1416-100		# 24 ~ # 20	0.2 ~ 0.5	φ 3.8 max.
Reel (3,500pcs/reel)	CE01- # 16P-2024-3500	CE01- # 16S-2024-3500		# 20 ~ # 16	0.5 ~ 1.25	
	CE01- # 16P-1620-3500	CE01- # 16S-1620-3500		# 14	2.0	
Separate (10pcs/bag)	CE01- # 12P-C1M-10	CE01- # 12S-C1M-10		# 24 ~ # 20	0.2 ~ 0.5	
	CE01- # 08P-C2M-10	CE01- # 08S-C2M-10	# 20 ~ # 16	0.5 ~ 1.25		
	CE01- # 08P-C1M-10	CE01- # 08S-C1M-10	# 14	2.0		
Machine	CE01- # 12P-C1M-10	CE01- # 12S-C1M-10	# 16 ~ # 12	1.25 ~ 3.5	φ 4.65 max.	
	CE01- # 08P-C2M-10	CE01- # 08S-C2M-10	# 12 ~ # 10	3.5 ~ 5.5	φ 7.25 max.	
	CE01- # 08P-C1M-10	CE01- # 08S-C1M-10	# 10 ~ # 8	5.5 ~ 8		

▶ Hand Crimping Tools

Contact Part Number	Applicable Cable		Tool Kit Part Number	Crimping Tool	Locator	Stopper	Inspection Gauge	Extraction Tool
	AWG #	Sectional area						
CE01- # 08P-C1M CE01- # 08S-C1M	8 ~ 10	5.5 ~ 8.0mm ²	357J-12605 (Note1)		357J-12606	357J-12607	357J-12724	357J-12609
CE01- # 08P-C2M CE01- # 08S-C2M	10 ~ 12	3.5 ~ 5.5mm ²				357J-12608		357J-12612
CE01- # 12P-C1M CE01- # 12S-C1M	12 ~ 16	1.25 ~ 3.5mm ²	357J-12725 (Note2)	357J-12610	357J-12611		357J-12723 (Note3)	
CE01- # 16P-1416 CE01- # 16S-1416	14	2.0mm ²		357J-13426				
CE01- # 16P-1620 CE01- # 16S-1620	16 ~ 20	0.5 ~ 1.25mm ²		357J-13411				357J-12615
CE01- # 16P-2024 CE01- # 16S-2024	20 ~ 24	0.2 ~ 0.5mm ²		357J-13412				
CE01- # 20P-C1 CE01- # 20S-C1	18 ~ 22	0.3 ~ 0.75mm ²		357J-13413				357J-13979
CE01- # 20P-C2 CE01- # 20S-C2	22 ~ 26	0.15 ~ 0.3mm ²		357J-13414				

Note 1 : 357J-12605 is a tool kit part number which includes the crimping tool, 357J-12606, 357J-12607, 357J-12608 and 357J-12724.
The crimping tool can not be sold alone separately.

Note 2 : 357J-12725 is a tool kit part number which includes the crimping tool, the locator and the inspection gauge.

Note 3 : 357J-12723 is a part number which contains 3 pieces of the inspection gauges.

Note 4 : The tool instruction manuals are available. Contact the nearest sales office or distributor.

▶ Semi-Automatic Crimping Machine

Contact Part Number	Stripper / Crimper			Crimping Machine		
	Kit	Press	Applicator	Kit	Press	Applicator
CE01- # 16P-1416 CE01- # 16S-1416				AP-A13607	CMP-300S	AP-A13607-1
CE01- # 16P-1620 CE01- # 16S-1620	AP-A11215	SCM-300S	AP-A11215-1	AP-A11216	CMP-300S	AP-A11216-1
CE01- # 16P-2024 CE01- # 16S-2024	AP-A13608	SCM-300S	AP-A13608-1	AP-A13609	CMP-300S	AP-A13609-1
CE01- # 20P-C1 CE01- # 20S-C1	AP-A13610	SCM-300S	AP-A13610-1	AP-A13611	CMP-200S-CB	AP-A13611-1
CE01- # 20P-C2 CE01- # 20S-C2	AP-A13612	SCM-300S	AP-A13612-1	AP-A13614	CMP-200S-CB	AP-A13614-1

■ Note

- #20 contacts are quite smaller in outer diameter than #16 contacts. Insert #20 contacts into the insert with care so as not to damage or deform the contacts.
- Make sure that all contacts remain fixed in the insert completely. Around the last 2 or 3 pieces of contacts should be taken care in particular for a larger number of the contact arrangements. It is relatively harder to insert the contacts after installing a large number of contacts into the insert since there are many wires on the wiring side.
- Use the mating half of CE01 series pin contacts when you test the electrical continuity of the socket contacts. In case of mating the other conductors such like a clip it causes the troubles of electrical continuity, contact retaining force or contact surface damage.